

Model SS053 Universal Voltage Regulator

www.mcphersoncontrols.com

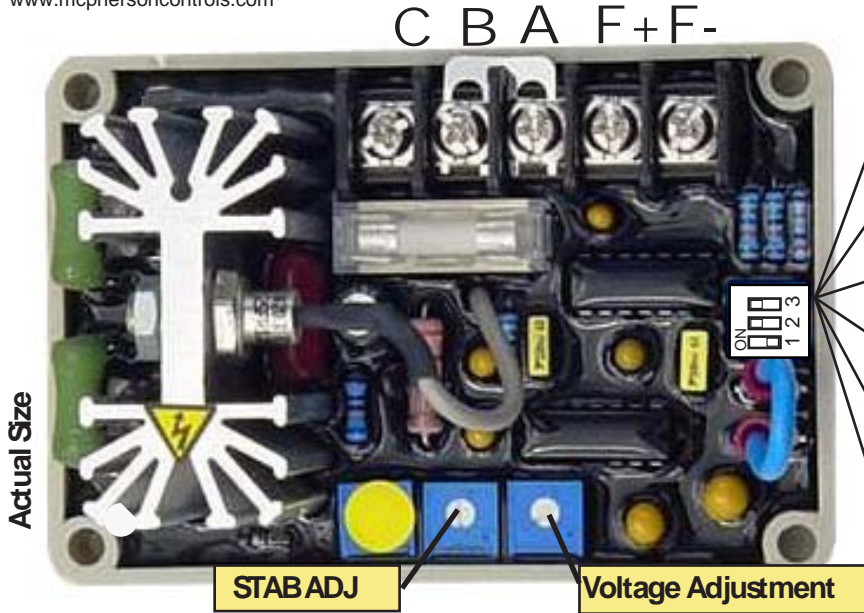

Actual Size

	220/127 Volts/50 Hertz
	208/120 Volts/60 Hertz 240/120 1 Phase 60 Hertz 240/120 Delta 60 Hertz
	380/220 Volts/50 Hertz
	380/220 Volts/60 Hertz 415/240 Volts/60 Hertz
	440 Volts 50 Hertz
	480/277 Volts/60 Hertz

Warning Connecting The AVR to the wrong voltage and programming it wrong can cause High Voltage Output that will burn your panel and equipment

4 Wire Method Jumper from A to B connected

SS053 is factory set for 240V 60Hz with a short from (B to A) and the dip switches set at (1 OFF) - (2 ON) - (3 ON)

In this configuration It works like most AVR's in any 12 wire generators sets from 190 to 277 volts with the exciter field from 13 to 100 Ohms.

In this configuration the power and sensing are connected together into terminals C & BA, and the output terminals are connected to F+ and F-. Like this it can work in a multitude of configuration. See Fig 1, 2, 3, and 4.

4 Wire Method

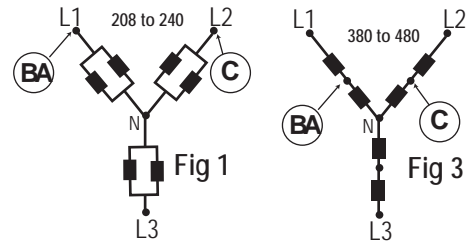

BEST WAY 5 Wire Method Remove Jumper from B to A

This method enhances the accuracy and output voltage balance of the AVR because it monitors the output of the AVR directly. This is the best way to install the AVR.

By using this method this AVR can work with almost any modern generator, even with European style generators with separate power winding. (see back page)

Remove and discard jumper (B to A), program DIP switches on the AVR to your generator's output voltage and frequency. Then connect generator terminals (L1 to C) and (L2 to A) and finally the (Neutral to B) (see Fig.5)

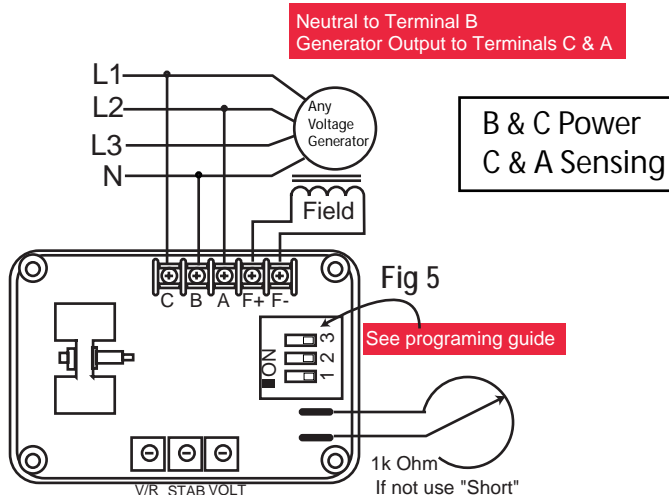
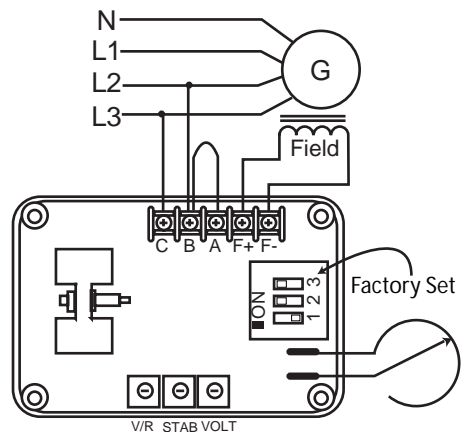
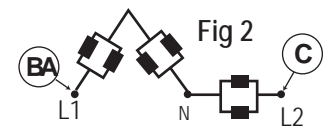
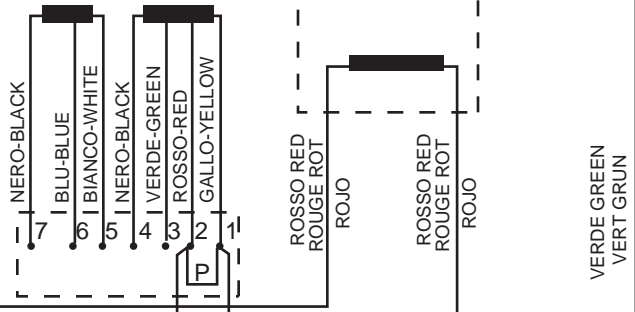
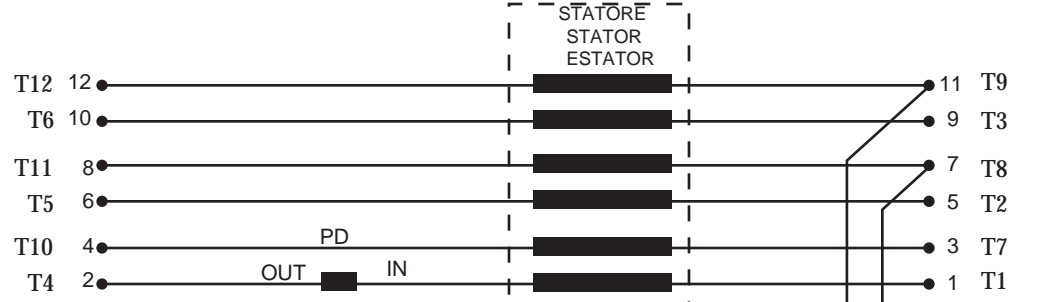
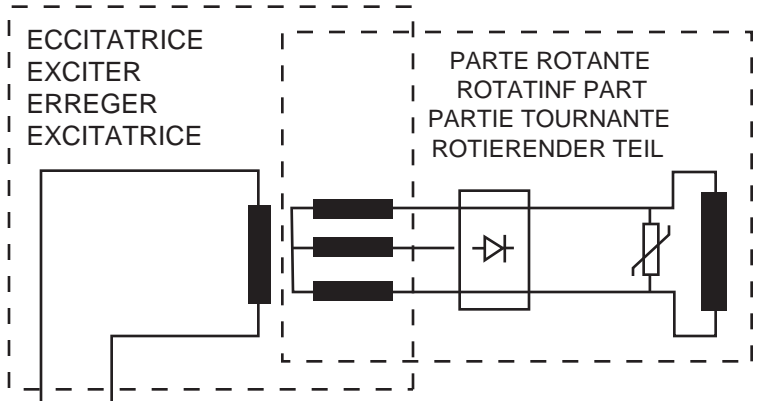

Fig 4

Fig 5



SAE to Mecc Alte

T1=1
T2=5
T3=9
T4=2
T5=6
T6=10
T7=3
T8=7
T9=11
T10=4
T11=8
T12=12

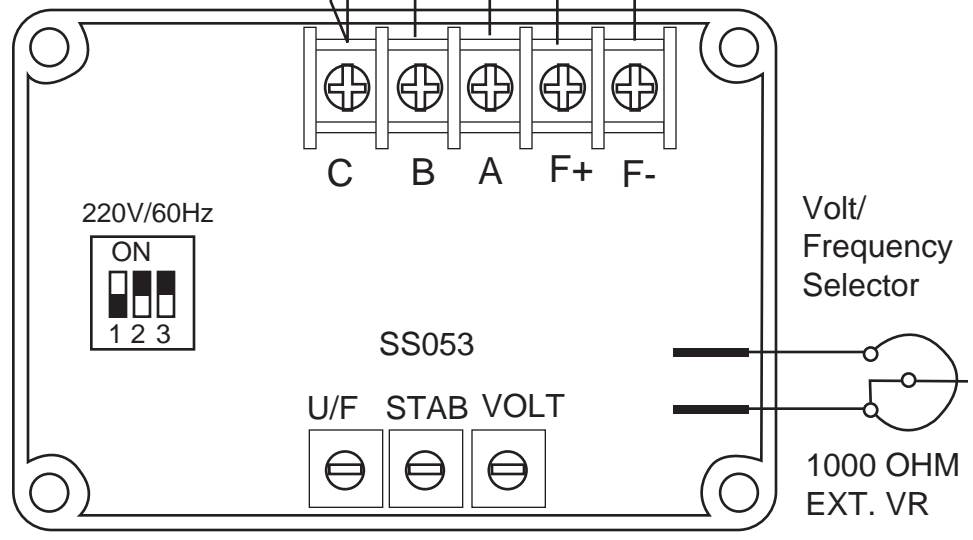

Same drawing presented differently

